

Trizeps VIII Mini

Documentation version 3.1

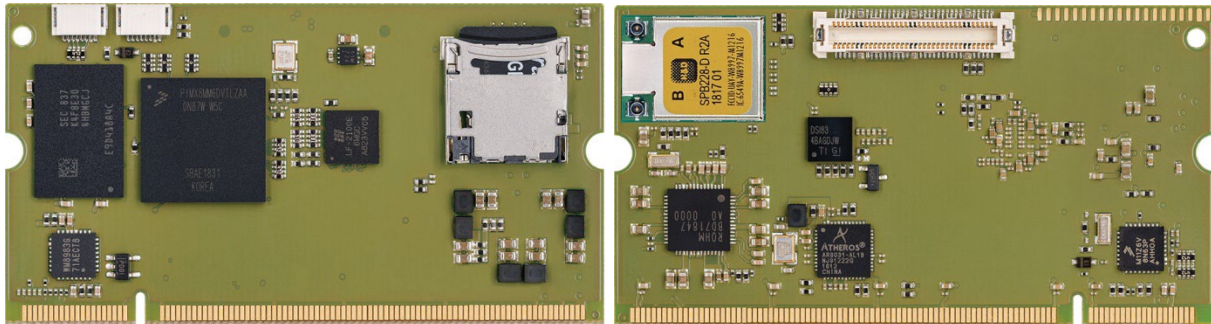

Front

Back

Introduction

The Trizeps VIII Mini is powered by NXP i.MX 8M Mini processor, which is designed to meet the latest market requirements of connected streaming audio/video devices, scanning/imaging devices and various devices demanding high-performance and low-power.

The i.MX 8M Mini family of processors features advanced implementation of a quad ARM[®] Cortex[®] A53 core, which operates at speeds of up to 1.8GHz (consumer version) and 1.6GHz (industrial version).

A general purpose Cortex[®]-M4 core processor is for low-power processing. A 32-bit LPDDR4 is used for memory. There are a number of other i.MX 8M Mini interfaces for connecting peripherals, such as displays, cameras, GPS and sensors, which are extended by components already available on the module:

- a stereo, hi-fi quality audio-codec.
- a FPGA with up to 4300 LUT to convert parallel display/camera/data-streams to/from MIPI and for user defined programmable logic.
- a programmable Cortex-M0 for realtime processing, capable of reading multiple 16bit analog inputs, usable as resistive touch-controller and for CAN communication.
- WLAN 802.11 a/b/g/n/ac and BT 4.2 and 5 ready module

SODIMM Standard

The Trizeps VIII Mini features the SECO SODIMM 200 Standard, the world's longest existing SODIMM standard. Like no other module standard, the SODIMM 200 ensures the pin compatibility of the Trizeps modules.

The main difference of the Trizeps VIII Mini is the missing address/data bus, which is no longer supported by the i.MX 8M Mini CPU. The pins, which are no longer needed for this function, are used for GBit Ethernet signals. Trizeps VIII Mini and Trizeps VIII are mostly pin compatible.

Block Diagram

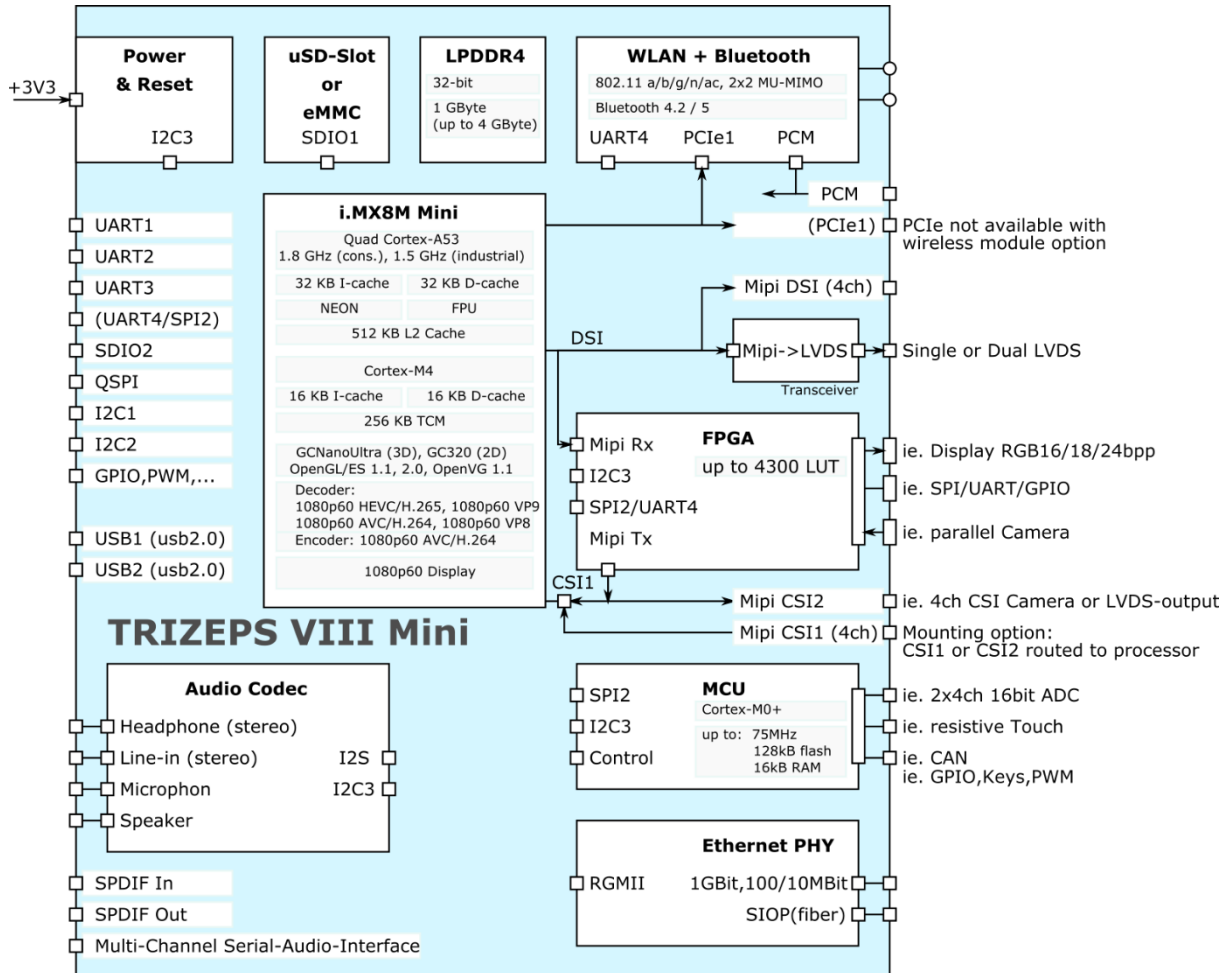

Figure 0-1: Simplified Block Diagram of Trizeps VIII Mini

The Trizeps VIII Mini module got a SODIMM200 card edge connector and a 60pin FX11 high-speed board connector. The pinning of both connectors is to a large extent compatible to previous Trizeps modules.



Features and Interfaces

Features

Processor:

NXP i.MX 8M Mini ARM® Quad Cortex-A53 at up to 1.8GHz (consumer), 1.6GHz (industrial)

NXP i.MX 8M Mini ARM® Cortex-M4

NXP Kinetis V ARM® Cortex-M0+ at up to 75MHz

Memory:

1 or 2 GByte of 32-bit LPDDR4-3200

Higher densities are available on request.

Storage:

Micro-SD socket or

4 or 8 GByte eMMC

Higher densities are available on request.

Wireless:

WLAN 802.11 a/b/g/n/ac

BT 4.2 and BT 5.0 ready

Micro RF-antenna connector

Power:

PMIC to generate all internal and external voltages from 3.3V supply.

Dimensions:

(Length x Width x Height): 67.6 x 36.7 x 6.4 mm

Interfaces / Signals accessible over connectors

- Power Supply through +3.3V.
- 2x USB2.0 OTG port (USB Host or Slave).
- PCIe
- SD/SDIO Card Interface
- 4x UART
- SPI and Quad-SPI
- 2x I2C
- Mipi Display (4ch) or Single/Dual LVDS or parallel RGB Display.
- 1x Mipi Camera (4ch).
- 1Gbit, 100/10Mbit Ethernet
- 1x CAN
- 2x 4ch 16bit ADC
- Stereo Headphone
- Stereo Line-In
- Microphone input
- 1W Speaker output
- SPDIF In and Out
- Multi-Channel Serial-Audio-Interface
- GPIO, PWM

1 PIN-DESCRIPTION

The main connector of the Trizeps VIII Mini is the SODIMM200 connector.
 To operate, only +3V3 and GND pins need to be connected. Leave unused pins unconnected.
 The U14 Board2Board connector can be omitted if the signals are not needed.
 J1 and J2 may be used for debugging, programming and testing.
 On the bottom side are UFL antenna connectors for the on-board WLAN + BT chip.

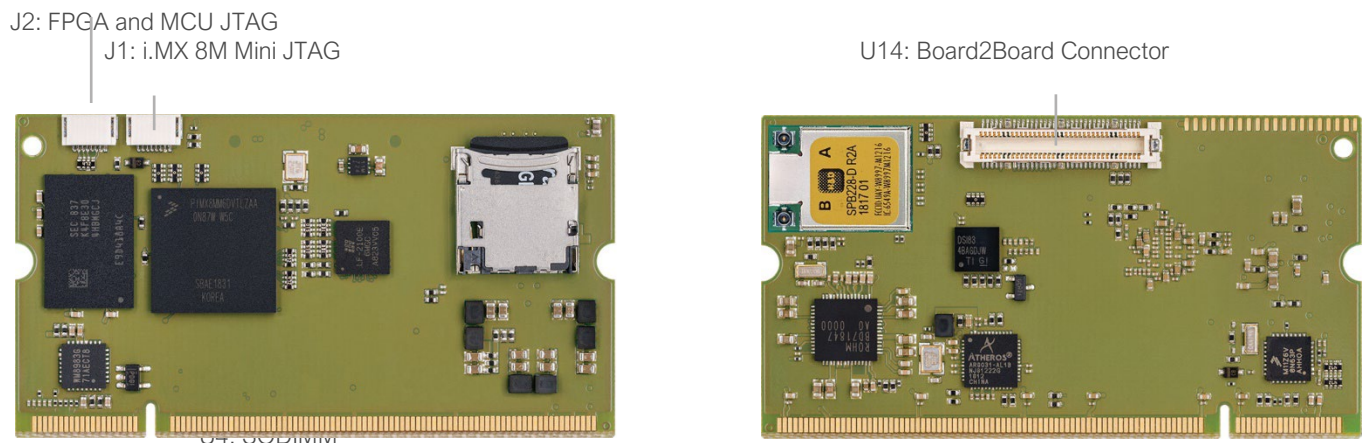

Figure 1-1: Connectors

1.1 Pin-Description (Primary Function)

The i.MX8M Mini processor, the Cortex M0+ MCU and the FPGA are highly configurable devices, where each pin may have multiple different functions.
 The pin-names are derived from previous Trizeps-versions and their primary or most interesting function.
 Please view chapter “1.2 Pin-Mux Information” for details on how these pins may be configured by software.

Notes:

- *1) In the table below, some of the old Trizeps pin-names are placed in brackets [] for reference.
- *2) FPGA_CIF_D[9..0] / SAIx_RXD[7..0], FPGA_CIF_HSYNC, FPGA_CIF_MCLK and FPGA_CIF_PCLK are routed to the FPGA and the i.MX 8M. In the following documentation they are either named FPGA_CIF_Dx or SAIx_RXDy, depending if the FPGA or i.MX 8M function is described.
- *3) FPGA_CIF_VSYNC, FPGA_CIF_HSYNC, FPGA_CIF_MCLK and FPGA_CIF_PCLK are connected to i.MX 8M pins, if the FPGA is not mounted (RA3).
- *4) BT_PCM_IN, BT_PCM_OUT, BT_PCM_SYNC and BT_PCM_CLK are connected to the on-board BT-module if it is mounted!
- *5) PCIE_CLKREQ may not be usable when Wifi module is mounted.



J500: SODIMM Connector

Signal	Pin		Pin	Signal
AUDIO_MIC_OUT	1		2	VIN_AD3 (MCU)
AUDIO_MIC_GND	3		4	VIN_AD2 (MCU)
AUDIO_LINEIN_L	5		6	VIN_AD1 (MCU)
AUDIO_LINEIN_R	7		8	VIN_AD0 (MCU)
AUDIO_AGND	9		10	AUDIO_VDDA
AUDIO_AGND	11		12	AUDIO_VDD_SPEAKER
AUDIO_HEADPHONE_GND	13		14	TSPX (MCU)
AUDIO_HEADPHONE_L	15		16	TSMX (MCU)
AUDIO_HEADPHONE_R	17		18	TSPY (MCU)
UART3_RXD	19		20	TSMY (MCU)
UART3_TXD	21		22	SPIN22_RTS3
UART1_DTR	23		24	SPIN24_CTS3
UART1_CTS	25		26	RESET_IN
UART1_RTS	27		28	SPEAKER_R
UART1_DSR	29		30	SPEAKER_L
UART1_DCD	31		32	UART2_CTS
UART1_RXD	33		34	UART2_RTS
UART1_TXD	35		36	UART2_RXD
UART1_RI	37		38	UART2_TXD
GND	39		40	VCC (+3V3)
GND	41		42	VCC (+3V3)
SPIN43	43		44	FPGA_LCD_DE
SPIN45	45		46	FPGA_LCD_D07
SD2_CLK	47		48	FPGA_LCD_D09
SAI1_RXD0	49		50	FPGA_LCD_D11
SD2_DATA3	51		52	FPGA_LCD_D12
SAI1_RXD1	53		54	FPGA_LCD_D13
SPIN55	55		56	FPGA_LCD_PCLK
SAI1_RXD2	57		58	FPGA_LCD_D03
SD2_DETECT	59		60	FPGA_LCD_D02
SAI1_RXD3	61		62	FPGA_LCD_D08
SAI1_RXD4	63		64	FPGA_LCD_D15
SAI1_RXD5	65		66	FPGA_LCD_D14
SAI1_RXD6	67		68	FPGA_LCD_HSYNC
LED_GPIO	69		70	FPGA_LCD_D01
SAI1_RXD7	71		72	FPGA_LCD_D05
SAI5_RXD1	73		74	FPGA_LCD_D10
SAI5_RXD2	75		76	FPGA_LCD_D00
BACKLIGHT_PWM	77		78	FPGA_LCD_D04
POWERFAIL	79		80	FPGA_LCD_D06
SD2_DATA1	81		82	FPGA_LCD_VSYNC



GND	83		84	VCC (+3V3)
SD2_DATA2	85		86	FPGA_CIF_VSYNC (*3)
RESET_OUT	87		88	SAI1_MCLK (*3)
+3V3_AUX	89		90	SAI1_RXC (*3)
+3V3_AUX	91		92	SAI1_RXFS (*3)
SPIN93 [RD/WR]	93		94	I2C1_SCL
SPIN95 [RDY]	95		96	I2C1_SDA
CAN1_RX (MCU)	97		98	GPIO_AUX
CAN1_TX (MCU)	99		100	DISPLAY_ENABLE
SPIN101	101		102	AUDIO_ENABLE
SPIN103	103		104	SPIN104
QSPI_SCLK [cs1]	105		106	SAI5_MCLK
QSPI_SS0 [cs3]	107		108	VCC (+3V3)
GND	109		110	SAI1_TXD0 [A08]
QSPI_DATA0 [A00]	111		112	SAI1_TXD1 [A09]
QSPI_DATA1 [A01]	113		114	SAI1_TXD2 [A10]
PCIE_CLKREQ (*5)	115		116	SAI1_TXD3 [A11]
QSPI_DATA2 [A03]	117		118	SAI1_TXD4 [A12]
QSPI_DATA3 [A04]	119		120	SAI1_TXD5 [A13]
SPIN121 [A05]	121		122	SAI1_TXD6 [A14]
CSI1_PWDN [A06]	123		124	SAI1_TXD7 [A15]
CSI1_RESET [A07]	125		126	SAI1_TXFS [DQM0]
USB1_PEN	127		128	SAI1_TXC [DQM1]
USB2_PEN	129		130	-
USB2_OC	131		132	SPIN132
USB1_OC	133		134	SPIN134
USB1_VBUS	135		136	SPIN136
USB1_ID	137		138	-
USB1_DP	139		140	-
USB1_DN	141		142	-
USB2_DP	143		144	-
USB2_DN	145		146	BT_PCM_IN [A19] (*4)
GND	147		148	VCC (+3V3)
-	149		150	FPGA_LCD_D16
-	151		152	FPGA_LCD_D17
-	153		154	PCIE_WAKE
-	155		156	VDD_FPGA_MIPI
-	157		158	PCIE_REFCLK_N
SPDIF_IN [D05]	159		160	PCIE_REFCLK_P
SPDIF_OUT [D06]	161		162	PCIE_TXN_P
SPDIF_EXT_CLK [D07]	163		164	PCIE_TXN_N
-	165		166	PCIE_RXN_P
-	167		168	PCIE_RXN_N



VDD_ENET_IO [D10]	169		170	FPGA_LCD_D21
ETH_LED_SPEED1000 [D11]	171		172	FPGA_LCD_D20
ETH_TRX2_N [D12]	173		174	FPGA_LCD_D19
ETH_TRX2_P [D13]	175		176	FPGA_LCD_D18
ETH_TRX3_N [D14]	177		178	FPGA_LCD_D23
ETH_TRX3_P [D15]	179		180	FPGA_LCD_D22
GND	181		182	VCC (+3V3)
ETH_LED_LINK_AKT	183		184	BT_PCM_OUT (*4)
ETH_LED_SPEED	185		186	BT_PCM_CLK (*4)
ETH_TRX0_N	187		188	BT_PCM_SYNC (*4)
ETH_TRX0_P	189		190	SD2_CMD
ETH_GND	191		192	SD2_DATA0
ETH_TRX1_N	193		194	I2C2_SDA
ETH_TRX1_P	195		196	I2C2_SCL
GND	197		198	VCC (+3V3)
GND	199		200	VCC_SNVS (+3V3)



J400: Board2Board Connector

Signal	Pin		Pin	Signal
MIPI_CSI1_D2_P	1		2	MIPI_DSI_D3_P
MIPI_CSI1_D2_N	3		4	MIPI_DSI_D3_N
MIPI_CSI1_D3_P	5		6	MIPI_DSI_D2_P
MIPI_CSI1_D3_N	7		8	MIPI_DSI_D2_N
-	9		10	LVDS1_TX2_P
GND	11		12	GND
-	13		14	LVDS1_TX2_N
-	15		16	LVDS1_TX3_N
-	17		18	LVDS1_TX3_P
-	19		20	LVDS1_CLK_P
-	21		22	LVDS1_CLK_N
-	23		24	LVDS1_TX0_P
-	25		26	LVDS1_TX0_N
-	27		28	LVDS1_TX1_P
-	29		30	LVDS1_TX1_N
MIPI_DSI_D1_P	31		32	MIPI_DSI_D1_N
GND	33		34	GND
LVDS0_TX1_N	35		36	MIPI_DSI_CLK_N
LVDS0_TX1_P	37		38	MIPI_DSI_CLK_P
LVDS0_TX0_P	39		40	-
LVDS0_TX0_N	41		42	-
LVDS0_CLK_N	43		44	-
LVDS0_CLK_P	45		46	-
LVDS0_TX2_P	47		48	-
LVDS0_TX2_N	49		50	-
LVDS0_TX3_P	51		52	-
LVDS0_TX3_N	53		54	-
GND	55		56	GND
MIPI_DSI_D0_N	57		58	-
MIPI_DSI_D0_P	59		60	-
MIPI_CSI1_D0_N	61		62	MIPI_CSI1_CLK_N
MIPI_CSI1_D0_P	63		64	MIPI_CSI1_CLK_P
MIPI_CSI1_D1_P	65		66	MIPI_CSI1_D1_N
GND	67		68	GND



J1: i.MX8M JTAG Connector

This flex-cable-connector uses the SECO JTAG connector standard. An Adapter to Multi-ICE pin-header is available.

Pin	Signal
1	+3V3_AUX
2	GND
3	JTAG_TMS
4	JTAG_TRST_N
5	JTAG_TCK
6	JTAG_TDO
7	JTAG_TDI
8	JTAG_RESET_N

J2: FPGA & MCU JTAG Connector

This flex-cable-connector uses the SECO JTAG connector standard. An adapter to Multi-ICE pin-header is available.

Pin	Signal
1	VDD_FPGA_MIPI
2	GND
3	FPGA_JTAG_TMS
4	SWD_CLK
5	FPGA_JTAG_TCK
6	FPGA_JTAG_TDO
7	FPGA_JTAG_TDI
8	SWD_DIO

1.2 Pin-Mux Information

Several pins are GPIOs which may be configured for different functions by software. Please check with the processor datasheet for additional pin-mux information.

An Excel-Sheet with pin-information is available at:

<https://documentation.seco.com/service/doku.php/service/hardware/module/sodimm200>

Notes:

*2) FPGA_CIF_D[9..0] / SAIx_RXD[7..0], FPGA_CIF_HSYNC, FPGA_CIF_MCLK and FPGA_CIF_PCLK are routed to the FPGA and the i.MX 8M Mini. In the following documentation they are either named FPGA_CIF_Dx or SAIx_RXDy, depending if the FPGA or i.MX 8M Mini function is described.

*3) FPGA_CIF_VSYNC, FPGA_CIF_HSYNC, FPGA_CIF_MCLK and FPGA_CIF_PCLK are connected to i.MX 8M Mini pins, if the FPGA is not mounted (RA3).

*4) BT_PCM_IN, BT_PCM_OUT, BT_PCM_SYNC and BT_PCM_CLK are connected to the on-board BT-module if it is mounted!

*5) PCIE_CLKREQ may not be usable when Wifi module is mounted.



1.2.1 i.MX 8M Mini pins

The i.MX 8M Mini pins got up to 10 different functions. Only the more common used are listed.

PIN	Name	Alt0	Alt1	Alt2 / Alt3	Alt5
19	UART3_RXD	ecspi1.SCLK	uart3.RX		gpio5.IO[6]
21	UART3_TXD	ecspi1_MOSI	uart3.TX		gpio5.IO[7]
22	SPIN22_RTS3	ecspi1.MISO	uart3.CTS_B		gpio5.IO[8]
23	UART1_DTR	sai5.RX_SYNC	sai1.TX_DATA[0]		gpio3.IO[19]
24	SPIN24_CTS3	ecspi1.SS0	uart3.RTS_B		gpio5.IO[9]
25	UART1_CTS	uart3.TX	uart1.RTS_B		gpio5.IO[27]
27	UART1_RTS	uart3.RX	uart1.CTS_B		gpio5.IO[26]
29	UART1_DSR	sai5.RX_BCLK	sai1.TX_DATA[1]		gpio3.IO[20]
31	UART1_DCD	sai2.RX_SYNC	sai5.TX_SYNC	sai5.TX_DATA[1]	gpio4.IO[21]
32	UART2_CTS	uart4.TX	uart2.RTS_B		gpio5.IO[29]
33	UART1_RXD	uart1.RX	ecspi3.SCLK		gpio5.IO[22]
34	UART2_RTS	uart4.RX	uart2.CTS_B	pcie1.CLKREQ_B	gpio5.IO[28]
35	UART1_TXD	uart1.TX	ecspi3.MOSI		gpio5.IO[23]
36	UART2_RXD	uart2.RX	ecspi3.MISO		gpio5.IO[24]
37	UART1_RI	sai2.RX_BCLK	sai5.TX_BCLK		gpio4.IO[22]
38	UART2_TXD	uart2.TX	ecspi3.SS0		gpio5.IO[25]
43	SPIN43	gpio1.IO[7]	enet1.MDIO		usdhc1.WP
45	SPIN45	rawnand.CE3_B	qspi.B_SS1_B		gpio3.IO[4]
47	SD2_CLK	usdhc2.CLK			gpio2.IO[13]
49	SAI1_RXD0	sai1.RX_DATA[0]	sai5.RX_DATA[0]	sai1.TX_DATA[1]	gpio4.IO[2]
51	SD2_DATA3	usdhc2.DATA3			gpio2.IO[18]
53	SAI1_RXD1	sai1.RX_DATA[1]	sai5.RX_DATA[1]		gpio4.IO[3]
55	SPIN55	sai5.RX_DATA[0]	sai1.TX_DATA[2]		gpio3.IO[21]
57	SAI1_RXD2	sai1.RX_DATA[2]	sai5.RX_DATA[2]		gpio4.IO[4]
59	SD2_DET	usdhc2.CD_B			gpio2.IO[12]
61	SAI1_RXD3	sai1.RX_DATA[3]	sai5.RX_DATA[3]		gpio4.IO[5]
63	SAI1_RXD4	sai1.RX_DATA[4]	sai6.TX_BCLK	sai6.RX_BCLK	gpio4.IO[6]
65	SAI1_RXD5	sai1.RX_DATA[5]	sai6.TX_DATA[0]	sai6.RX_DATA[0] sai1.RX_SYNC	gpio4.IO[7]
67	SAI1_RXD6	sai1.RX_DATA[6]	sai6.TX_SYNC	sai6.RX_SYNC	gpio4.IO[8]
69	LED_GPIO	sai3.MCLK	pwm4.OUT	sai5.MCLK	gpio5.IO[2]
71	SAI1_RXD7	sai1.RX_DATA[7]	sai6.MCLK	sai1.TX_SYNC sai1.TX_DATA[4]	gpio4.IO[9]
73	SAI5_RXD1	sai5.RX_DATA[1]	sai1.TX_DATA[3]	sai1.TX_SYNC sai5.TX_SYNC	gpio3.IO[22]
75	SAI5_RXD2	sai5.RX_DATA[2]	sai1.TX_DATA[4]	sai1.TX_SYNC sai5.TX_BCLK	gpio3.IO[23]
77	BACKLIGHT_PWM	gpio1.IO[1]	pwm1.OUT		anamix.REF_CLK _24M
79	POWERFAIL	sai5.RX_DATA[3]	sai1.TX_DATA[5]	sai1.TX_SYNC sai5.TX_DATA[0]	gpio3.IO[24]



81	SD2_DATA1	usdhc2.DATA1			gpio2.IO[16]
85	SD2_DATA2	usdhc2.DATA2			gpio2.IO[17]
86	FPGA_CIF_VSYNC *3)	ecspi2.SS0	uart4.RTS_B		gpio5.IO[13]
87	RESET_OUT	gpio3.IO[14]			
88	SAI1_MCLK	sai1.MCLK	sai5.MCLK	sai1.TX_BCLK	gpio4.IO[20]
90	SAI1_RXC	sai1.RX_BCLK	sai5.RX_BCLK		gpio4.IO[1]
92	SAI1_RXFS	sai1.RX_SYNC	sai5.RX_SYNC		gpio4.IO[0]
93	SPIN93	rawnand.WP_B			gpio3.IO[18]
94	I2C1_SCL	i2c1.SCL	enet1.MDC		gpio5.IO[14]
95	SPIN95	rawnand.READY_ B			gpio3.IO[16]
96	I2C1_SDA	i2c1.SDA	enet1.MDIO		gpio5.IO[15]
98	SPIN98	gpio1.IO[0]	ccmsrcgpcmix.ENABLE T_PHY_REF_CLK_ ROOT		anamix.REF_CLK_ _32K
100	DISPLAY_ENABLE	gpio1.IO[5]	m4.NMI		ccmsrcgpcmix.F MIC_READY
101	SPIN101	sai3.TX_SYNC	gpt1.CAPTURE2	sai5.RX_DATA[1]	gpio4.IO[31]
102	AUDIO_ENABLE	gpio1.IO[8]	enet1.1588_EVENT_ 0_IN		usdhc2.RESET_ B
103	SPIN103	sai3.TX_BCLK	gpt1.COMPARE2	sai5.RX_DATA[2]	gpio5.IO[0]
104	SPIN104	rawnand.DATA05	qspi.B_DATA[1]		gpio3.IO[11]
105	QSPI_SCLK	rawnand.ALE	qspi.A_SCLK		gpio3.IO[0]
106	SAI5_MCLK	sai5.MCLK	sai1.TX_BCLK		gpio3.IO[25]
107	QSPI_SS0	rawnand.CE0_B	qspi.A_SS0_B		gpio3.IO[1]
110	SAI1_TXD0	sai1.TX_DATA[0]	sai5.TX_DATA[0]		gpio4.IO[12]
111	QSPI_DATA0	rawnand.DATA00	qspi.A_DATA[0]		gpio3.IO[6]
112	SAI1_TXD1	sai1.TX_DATA[1]	sai5.TX_DATA[1]		gpio4.IO[13]
113	QSPI_DATA1	rawnand.DATA01	qspi.A_DATA[1]		gpio3.IO[7]
114	SAI1_TXD2	sai1.TX_DATA[2]	sai5.TX_DATA[2]		gpio4.IO[14]
115	PCIE_CLKREQ (*5)	i2c4.SCL	pwm2.OUT	pcie1.CLKREQ_B	gpio5.IO[20]
116	SAI1_TXD3	sai1.TX_DATA[3]	sai5.TX_DATA[3]		gpio4.IO[15]
117	QPSPI_DATA2	rawnand.DATA02	qspi.A_DATA[2]		gpio3.IO[8]
118	SAI1_TXD4	sai1.TX_DATA[4]	sai6.RX_BCLK	sai6.TX_BCLK	gpio4.IO[16]
119	QSPI_DATA3	rawnand.DATA03	qspi.A_DATA[3]		gpio3.IO[9]
120	SAI1_TXD5	sai1.TX_DATA[5]	sai6.RX_DATA[0]	sai6.TX_DATA[0]	gpio4.IO[17]
121	SPIN121	rawnand.DATA04	qspi.B_DATA[0]		gpio3.IO[10]
122	SAI1_TXD6	sai1.TX_DATA[6]	sai6.RX_SYNC	sai6.TX_SYNC	gpio4.IO[18]
123	CSI1_PWDN	gpio1.IO[3]	usdhc1.VSELECT		sdma1.EXT_EVENT[0]
124	SAI1_TXD7	sai1.TX_DATA[7]	sai6.MCLK		gpio4.IO[19]
125	CSI_RESET	gpio1.IO[6]	enet1.MDC		usdhc1.CD_B
126	SAI1_TXFS	sai1.TX_SYNC	sai5.TX_SYNC		gpio4.IO[10]



127	USB1_PEN	gpio1.IO[12]	usb1.OTG_PWR		sdma2.EXT_EVENT[1]
128	SAI1_TXC	sai1.TX_BCLK	sai5.TX_BCLK		gpio4.IO[11]
129	USB2_PEN	gpio1.IO[14]	usb2.OTG_PWR		pwm3.OUT
131	USB2_OC	gpio1.IO[15]	usb2.OTG_OC		pwm4.OUT
132	SPIN32	rawnand.DATA06	qspi.B_DATA[2]		gpio3.IO[12]
133	USB1_OC	gpio1.IO[13]	usb1.OTG_OC		pwm2.OUT
134	USB1_PD_INT	rawnand.CE2_B	qspi.B_SS0_B		gpio3.IO[3]
136	USB1_SS_SEL	rawnand.RE_B	qspi.B_DQS		gpio3.IO[15]
146	BT_PCM_IN *4)	sai3.TX_DATA[0]	gpt1.COMPARE3	sai5.RX_DATA[3]	gpio5.IO[1]
154	PCIE_WAKE	rawnand.DATA07	qspi.B_DATA[3]		gpio3.IO[13]
159	SPDIF_IN	spdif1.IN	pwm2.OUT		gpio5.IO[4]
161	SPDIF_OUT	spdif1.OUT	pwm3.OUT		gpio5.IO[3]
163	SPDIF_EXT_CLK	spdif1.EXT_CLK	pwm1.OUT		gpio5.IO[5]
184	BT_PCM_OUT *4)	sai3.RX_DATA[0]	gpt1.COMPARE1	sai5.RX_DATA[0]	gpio4.IO[30]
186	BT_PCM_CLK *4)	sai3.RX_BCLK	gpt1.CLK	sai5.RX_BCLK	gpio4.IO[29]
188	BT_PCM_SYNC *4)	sai3.RX_SYNC	gpt1.CAPTURE1	sai5.RX_SYNC	gpio4.IO[28]
190	SD2_CMD	usdhc2.CMD			gpio2.IO[14]
192	SD2_DATA0	usdhc2.DATA0			gpio2.IO[15]
194	I2C2_SDA	i2c2.SDA	enet1.1588_EVENT1_OUT		gpio5.IO[17]
196	I2C2_SCL	i2c2.SCL	enet1.1588_EVENT1_IN		gpio5.IO[16]



1.2.2 Kinetis MCU pins

Several pins are GPIOs which may be configured for different functions by software.

Please check with the microcontroller datasheet for additional pin-mux information.

PIN	Name	Alt0	Alt1	Alt2	Alt3	Alt4	Alt5	Alt6	Alt7
2	VIN_AD3	ADC0_SE7 ADC1_SE7 ADC1_DM1	PTE19	SPI0_SIN	UART1_RTS	I2C0_SCL		SPI0_SOUT	
4	VIN_AD2	ADC0_SE6 ADC1_SE1 ADC1_DP1	PTE18 LLWU_P20	SPI0_SOUT	UART1_CTS	I2C0_SDA		SPI0_SIN	
6	VIN_AD1	ADC0_DM1 ADC0_SE5 ADC1_SE5	PTE17 LLWU_P19	SPI0_SCK	UART1_RX	FTM_CLKIN1		LPTMR0_ALT3	
8	VIN_AD0	ADC0_SE1 ADC0_DP1 ADC1_SE0	PTE16	SPI0_PCS0	UART1_TX	FTM_CLKIN0		FTM_FLT3	
14	TSPX	ADC0_SE8 ADC1_SE8	PTB0 LLWU_P5	I2C0_SCL	FTM1_CH0			FTM1_QD_PHA	UART0_RX
16	TSMX	ADC0_SE9 ADC1_SE9	PTB1	I2C0_SDA	FTM1_CH1	FTM0_FLT2	EWM_IN	FTM1_QD_PHB	UART0_TX
18	TSPY	ADC0_SE11 CMP1_IN0	PTC2	SPI0_PCS2	UART1_CTS	FTM0_CH1	FTM2_CH1		
20	TSMY	ADC1_SE4 CMP1_IN4 DAC0_OUT	PTE30		FTM0_CH3		FTM_CLKIN1		
24	SPIN24_ CTS3		PTA4 LLWU_P3		FTM0_CH1	FTM4_FLT0	FTM0_FLT3		NMI_b
26	RESET_IN		PTA20						RESET
97	CAN1_RX		PTE25 LLWU_P21	CAN0_RX	FTM0_CH1		I2C0_SDA	EWM_IN	
99	CAN1_TX		PTE24	CAN0_TX	FTM0_CH0		I2C0_SCL	EWM_OUT	

*) Only MKV11 MCU, not usable with MKV10 MCU.

ADC_SE	Single-Ended ADC
ADC_DM/P	Differential ADC
LLWU	Wakeup-Sources
EWM	External Watchdog Monitor
FTM	Flexible Timer Module
FTM_CH	Output Channel
FTM_FLT	Fault
FTM_QD_PH	Quadrature Decoder



1.3 Electrical Pin-Information

PI:	Power Input	DO:	Digital Output
PO:	Power Output	DIO:	Digital Input/Output
AI:	Analog Input	DDI:	Differential Input
AO:	Analog Output	DDO:	Differential Output
		DDIO:	Differential Input/Output
DI:	Digital Input	OD:	Open-Drain Output
PD:	Pull-Down	(PDp: Pull-Down, Pull-behavior can be changed by software)	
PU:	Pull-Up	(PUp: Pull-Up, Pull-behavior can be changed by software)	

If two “Type” are specified, the first value determines the type of the primary-function.

SODIMM

PIN	Name	Type	Voltage	Connected to
1	AUDIO_MIC_OUT	AI		Audio-Codec
3	AUDIO_MIC_GND	AI		Audio-Codec
5	AUDIO_LINEIN_L	AI		Audio-Codec
7	AUDIO_LINEIN_R	AI		Audio-Codec
9	AUDIO_AGND	Analog Audio Ground		Audio-Codec and VREF- of Kinetis MCU
11	AUDIO_AGND			
13	AUDIO_HEADPHONE_GND	AI		Audio-Codec
15	AUDIO_HEADPHONE_L	AO		Audio-Codec
17	AUDIO_HEADPHONE_R	AO		Audio-Codec
19	UART3_RXD	DI, DIO	NVCC_3V3	i.MX8M and BT module, if no FPGA (RA600)
21	UART3_TXD	DO, DIO	NVCC_3V3	
23	UART1_DTR	DO, DIO	NVCC_3V3	i.MX8M
25	UART1_CTS	DI, DIO	NVCC_3V3	i.MX8M
27	UART1_RTS	DO, DIO	NVCC_3V3	i.MX8M
29	UART1_DSR	DI, DIO	NVCC_3V3	i.MX8M
31	UART1_DCD	DI, DIO	NVCC_3V3	i.MX8M
33	UART1_RXD	DI, DIO	NVCC_3V3	i.MX8M
35	UART1_TXD	DO, DIO	NVCC_3V3	i.MX8M
37	UART1_RI	DI, DIO	NVCC_3V3	i.MX8M
39	GND	Ground		
41	GND			
43	SPIN43	DIO	NVCC_3V3	i.MX8M
45	SPIN45	DIO	NVCC_3V3	i.MX8M
47	SD2_CLK	DO, DIO	NVCC_3V3	i.MX8M
49	SAI1_RXD0	DI, DIO	NVCC_3V3	i.MX8M
51	SD2_DATA3	DIO	NVCC_3V3	i.MX8M



53	i.MX8M	DI, DIO	NVCC_3V3	i.MX8M
55	SPIN55	DIO	NVCC_3V3	i.MX8M
57	FPGA_CIF_D2	DI, DIO	NVCC_3V3	Fi.MX8M
59	SD2_DET	DI, DIO	NVCC_3V3	i.MX8M
61	FPGA_CIF_D3	DI, DIO	NVCC_3V3	i.MX8M
63	FPGA_CIF_D4	DI, DIO	NVCC_3V3	i.MX8M
65	FPGA_CIF_D5	DI, DIO	NVCC_3V3	i.MX8M
67	FPGA_CIF_D6	DI, DIO	NVCC_3V3	i.MX8M
69	LED_GPIO, PWM4	DO, DIO	NVCC_3V3	i.MX8M
71	FPGA_CIF_D7	DI, DIO	NVCC_3V3	i.MX8M
73	FPGA_CIF_D8	DI, DIO	NVCC_3V3	i.MX8M
75	FPGA_CIF_D9	DI, DIO	NVCC_3V3	i.MX8M
77	BACKLIGHT_PWM	DO, DIO	NVCC_3V3	i.MX8M
79	POWERFAIL	DI, DIO	NVCC_3V3	i.MX8M
81	SD2_DATA1	DIO	NVCC_3V3	i.MX8M
83	GND	Ground		
85	SD2_DATA2	DIO	NVCC_3V3	i.MX8M
87	RESET_OUT	DO	NVCC_3V3	FPGA + i.MX8M + Kinetis MCU
89	+3V3_AUX (NVCC_3V3)	PO	+3V3	NVCC_3V3
91	+3V3_AUX (NVCC_3V3)			
93	SPIN93	DIO	NVCC_3V3	i.MX8M
95	SPIN95	DIO	NVCC_3V3	i.MX8M
97	CAN1_RX	DI, DIO	VCC_SNVS	Kinetis MCU
99	CAN1_TX	DO, DIO		
101	SPIN101	DIO	NVCC_3V3	i.MX8M
103	SPIN103	DIO	NVCC_3V3	i.MX8M
105	QSPI_SCLK (CS1)	DO, DIO	NVCC_3V3	i.MX8M
107	QSPI_SS0 (CS3)	DO, DIO	NVCC_3V3	i.MX8M
109	GND	Ground		
111	QSPI_DATA0 (A00)	DIO	NVCC_3V3	i.MX8M
113	QSPI_DATA1 (A01)	DIO	NVCC_3V3	i.MX8M
115	PCIE_CLKREQ	DIO	NVCC_3V3	i.MX8M
117	QPSPI_DATA2 (A03)	DIO	NVCC_3V3	i.MX8M
119	QSPI_DATA3 (A04)	DIO	NVCC_3V3	i.MX8M
121	SPIN121 (A05)	DIO	NVCC_3V3	i.MX8M
123	CSI1_PWDN	DO, DIO	NVCC_3V3	i.MX8M
125	CSI_RESET	DO, DIO	NVCC_3V3	i.MX8M
127	USB1_PEN	DO, DIO	NVCC_3V3	i.MX8M
129	USB2_PEN	DO, DIO	NVCC_3V3	i.MX8M
131	USB2_OC	DI, DIO	NVCC_3V3	i.MX8M
133	USB1_OC	DI, DIO	NVCC_3V3	i.MX8M
135	USB1_VBUS	DI (PO)	+5V	i.MX8M



137	USB1_ID	DI	NVCC_3V3	i.MX8M
139	USB1_DP	DDIO	NVCC_3V3	i.MX8M
141	USB1_DN	DDIO	NVCC_3V3	i.MX8M
143	USB2_DP	DDIO	NVCC_3V3	i.MX8M
145	USB2_DN	DDIO	NVCC_3V3	i.MX8M
147	GND	Ground		
149	-			
151	-			
153	-			
155	-			
157	-			
159	SPDIF_IN	DI, DIO	NVCC_3V3	i.MX8M
161	SPDIF_OUT	DO, DIO	NVCC_3V3	i.MX8M
163	SPDIF_EXT_CLK	DI, DIO	NVCC_3V3	i.MX8M
165	-			
167	-			
169	VDD_ENET_IO	PO	Ethernet signal IO voltage	
171	ETH_LED_SPEED1000	OD	NVCC_3V3	Gbit Ethernet-Phy
173	ETH_TRX2_N	DDIO	VDD_ENET_IO	Gbit Ethernet-Phy
175	ETH_TRX2_P	DDIO	VDD_ENET_IO	Gbit Ethernet-Phy
177	ETH_TRX3_N	DDIO	VDD_ENET_IO	Gbit Ethernet-Phy
179	ETH_TRX3_P	DDIO	VDD_ENET_IO	Gbit Ethernet-Phy
181	GND	Ground		
183	ETH_LED_LINK_AKT	OD	NVCC_3V3	Gbit Ethernet-Phy
185	ETH_LED_SPEED	OD	NVCC_3V3	Gbit Ethernet-Phy
187	ETH_TRX0_N	DDIO	VDD_ENET_IO	Gbit Ethernet-Phy
189	ETH_TRX0_P	DDIO	VDD_ENET_IO	Gbit Ethernet-Phy
191	ETH_GND	Ground		
193	ETH_TRX1_N	DDIO	VDD_ENET_IO	Gbit Ethernet-Phy
195	ETH_TRX1_P	DDIO	VDD_ENET_IO	Gbit Ethernet-Phy
197	GND	Ground		
199	GND			
2	VIN_AD3	AI, DIO	VCC_SNVS	Kinetis MCU, PTE16: ADC0_SE1
4	VIN_AD2	AI, DIO	VCC_SNVS	Kinetis MCU, PTE17: ADC0_SE5
6	VIN_AD1	AI, DIO	VCC_SNVS	Kinetis MCU, PTE18: ADC0_SE6
8	VIN_AD0	AI, DIO	VCC_SNVS	Kinetis MCU, PTE19: ADC0_SE7
10	AUDIO_VDDA	PI	AUDIO_VDD	Audio-Codec and VREF+ of Kinetis MCU
12	AUDIO_VDD_SPEAKER	PI	VDD_SPEAKER	Audio-Codec and VREF+ of Kinetis MCU



14	TSPX	AI, DIO	VCC_SNVS	Kinetis MCU, PTB0: ADC1_SE8
16	TSMX	AI, DIO	VCC_SNVS	Kinetis MCU, PTB1: ADC1_SE9
18	TSPY	AI, DIO	VCC_SNVS	Kinetis MCU, PTC2: ADC0_SE11, CMP1_IN0
20	TSMY	AI, DIO	VCC_SNVS	Kinetis MCU, PTE30: ADC1_SE4, CMP1_IN4
22	SPIN22_RTS3	DO, DIO	NVCC_3V3	i.MX8M and BT module, if no FPGA ^A (RA600)
24	SPIN24_CTS3	DI, DIO	NVCC_3V3 VCC_SNVS	Kinetis MCU, i.MX8M and BT module, if no FPGA (RA600) optional ONOFF (R627), optional BOOT_MODE0 (R628)
26	RESET_IN	DI	VCC_SNVS	Kinetis MCU and Reset-Circuit
28	SPEAKER_P	AO	VDD_SPEAKER	Audio-Codec
30	SPEAKER_N	AO		
32	UART2_CTS	DI, DIO	NVCC_3V3	i.MX8M
34	UART2_RTS	DO, DIO	NVCC_3V3	i.MX8M
36	UART2_RXD	DI, DIO	NVCC_3V3	i.MX8M
38	UART2_TXD	DO, DIO	NVCC_3V3	i.MX8M
40	VCC	PI	+3V3	
42	VCC			
44	FPGA_LCD_DE	DO, DIO	NVCC_3V3	FPGA
46	FPGA_LCD_D07	DO, DIO	NVCC_3V3	FPGA
48	FPGA_LCD_D09	DO, DIO	NVCC_3V3	FPGA
50	FPGA_LCD_D11	DO, DIO	NVCC_3V3	FPGA
52	FPGA_LCD_D12	DO, DIO	NVCC_3V3	FPGA
54	FPGA_LCD_D13	DO, DIO	NVCC_3V3	FPGA
56	FPGA_LCD_PCLK	DO, DIO	NVCC_3V3	FPGA
58	FPGA_LCD_D03	DO, DIO	NVCC_3V3	FPGA
60	FPGA_LCD_D02	DO, DIO	NVCC_3V3	FPGA
62	FPGA_LCD_D08	DO, DIO	NVCC_3V3	FPGA
64	FPGA_LCD_D15	DO, DIO	NVCC_3V3	FPGA
66	FPGA_LCD_D14	DO, DIO	NVCC_3V3	FPGA
68	FPGA_LCD_HSYNC	DO, DIO	NVCC_3V3	FPGA
70	FPGA_LCD_D01	DO, DIO	NVCC_3V3	FPGA
72	FPGA_LCD_D05	DO, DIO	NVCC_3V3	FPGA
74	FPGA_LCD_D10	DO, DIO	NVCC_3V3	FPGA



76	FPGA_LCD_D00	DO, DIO	NVCC_3V3	FPGA
78	FPGA_LCD_D04	DO, DIO	NVCC_3V3	FPGA
80	FPGA_LCD_D06	DO, DIO	NVCC_3V3	FPGA
82	FPGA_LCD_VSYNC	DO, DIO	NVCC_3V3	FPGA
84	VCC	PI	+3V3	
86	FPGA_CIF_VSYNC SPI2_SS0	DO, DIO	NVCC_3V3	FPGA, RA3 optional route to i.MX8M SPI2_SS0
88	FPGA_CIF_MCLK SPI2_SCLK	DO, DIO	NVCC_3V3	FPGA, RA3 optional route to i.MX8M SPI2_SCLK
90	FPGA_CIF_PCLK SPI2_MISO	DO, DIO	NVCC_3V3	FPGA, RA3 optional route to i.MX8M SPI2_MISO
92	FPGA_CIF_HSYNC SPI2_MOSI	DO, DIO	NVCC_3V3	FPGA, RA3 optional route to i.MX8M SPI2_MOSI
94	I2C1_SCL	DO, DIO	NVCC_3V3	i.MX8M
96	I2C1_SDA	DO, DIO	NVCC_3V3	i.MX8M
98	SPIN98	DIO	NVCC_3V3	i.MX8M
100	DISPLAY_ENABLE	DO, DIO	NVCC_3V3	i.MX8M
102	AUDIO_ENABLE	DO, DIO	NVCC_3V3	i.MX8M
104	SPIN104	DIO	NVCC_3V3	i.MX8M
106	SAI5_MCLK	DO, DIO	NVCC_3V3	i.MX8M
108	VCC	PI	+3V3	
110	SAI1_TXD0	DO, DIO	NVCC_3V3	i.MX8M
112	SAI1_TXD1	DO, DIO	NVCC_3V3	i.MX8M
114	SAI1_TXD2	DO, DIO	NVCC_3V3	i.MX8M
116	SAI1_TXD3	DO, DIO	NVCC_3V3	i.MX8M
118	SAI1_TXD4	DO, DIO	NVCC_3V3	i.MX8M
120	SAI1_TXD5	DO, DIO	NVCC_3V3	i.MX8M
122	SAI1_TXD6	DO, DIO	NVCC_3V3	i.MX8M
124	SAI1_TXD7	DO, DIO	NVCC_3V3	i.MX8M
126	SAI1_TXFS	DO, DIO	NVCC_3V3	i.MX8M
128	SAI1_TXC	DO, DIO	NVCC_3V3	i.MX8M
130	-			
132	SPIN32	DIO	NVCC_3V3	i.MX8M
134	USB1_PD_INT	DI, DIO	NVCC_3V3	i.MX8M
136	USB1_SS_SEL	DO, DIO	NVCC_3V3	i.MX8M
138	-			
140	-			
142	-			
144	-			
146	BT_PCM_IN	DI, DIO	NVCC_3V3	i.MX8M and BT- Module



148	VCC	PI	+3V3	
150	FPGA_LCD_D16	DO, DIO	NVCC_3V3	FPGA
152	FPGA_LCD_D17	DO, DIO	NVCC_3V3	FPGA
154	PCIE_WAKE	DO, DIO	NVCC_3V3	i.MX8M
156	VDD_FPGA_MIPI	PO	+2V5 (programmable)	
158	PCIE_REFCLK_N	DDO	NVCC_3V3	i.MX8M
160	PCIE_REFCLK_P	DDO	NVCC_3V3	i.MX8M
162	PCIE_TXN_P	DDO	NVCC_3V3	i.MX8M
164	PCIE_TXN_N	DDO	NVCC_3V3	i.MX8M
166	PCIE_RXN_P	DDI	NVCC_3V3	i.MX8M
168	PCIE_RXN_N	DDI	NVCC_3V3	i.MX8M
170	FPGA_LCD_D21	DO, DIO	NVCC_3V3	FPGA
172	FPGA_LCD_D20	DO, DIO	NVCC_3V3	FPGA
174	FPGA_LCD_D19	DO, DIO	NVCC_3V3	FPGA
176	FPGA_LCD_D18	DO, DIO	NVCC_3V3	FPGA
178	FPGA_LCD_D23	DO, DIO	NVCC_3V3	FPGA
180	FPGA_LCD_D22	DO, DIO	NVCC_3V3	FPGA
182	VCC	PI	+3V3	
184	BT_PCM_OUT	DO, DIO	NVCC_3V3	i.MX8M and BT-Module
186	BT_PCM_CLK	DO, DIO	NVCC_3V3	i.MX8M and BT-Module
188	BT_PCM_SYNC	DO, DIO	NVCC_3V3	i.MX8M and BT-Module
190	SD2_CMD	DO, DIO	NVCC_3V3	i.MX8M
192	SD2_DATA0	DIO	NVCC_3V3	i.MX8M
194	I2C2_SDA	DIO	NVCC_3V3	i.MX8M
196	I2C2_SCL	DIO	NVCC_3V3	i.MX8M
198	VCC	PI	+3V3	
200	VCC_SNVS	PI	+3V3 (Must be applied first)	

2 INTERFACES

This chapter includes a short description of all interfaces of the Trizeps VIII Mini. Please consult the processor datasheet for detailed information.

2.1 Power Supply

The Trizeps VIII Mini can be supplied by a single +3V3 power-supply. But it is possible to supply parts of the modules separately.

Name	Description
+3V3_SNVS	+3V3 power input. This supply powers the Kinetis MCU. The Kinetis MCU controls reset and power to the i.MX8M processor and may be programmed by customers.
+3V3	Main power input.
+3V3_AUX (NVCC_3V3)	+3V3 output. NVCC_3V3 is the IO-voltage for several peripherals of the i.MX8M Mini. State of GPIO-pins is undefined until +3V3_AUX is available!
AUDIO_VDD	+3V3 power input for audio. Also used as reference-voltage for ADC of Kinetis MCU.
AUDIO_VDD_SPEAKER	+3V3 or +5V power input for audio speaker.
AUDIO_AGND	Analog GND.
VDD_ENET_IO	+2V5 power output. Ethernet signal IO voltage.
VDD_FPGA_MIPi	+2V5 power output. Voltage is programmable and supplies the MIPi IO-banks of the FPGA.

2.2 Control-Signals

Name	Description
RESET_IN	Negated reset input. 0: reset device, 1: normal operation.
RESET_OUT	Negated reset output. 0: device in reset, 1: normal operation.
SPIN24_CTS3	Is connected to the programmable Kinetis MCU. i.e. may be used to control ONOFF or BOOT_MODE-pin of i.MX8M.



2.3 UART

The i.MX8M provides 4 Universal Asynchronous Receiver/Transmitter. With a transceiver these signals can be converted to RS232, RS485 or IrDA.

The SODIMM200 standard defines 3 UART ports, but all 4 UARTs are accessible through the SODIMM200 connector if needed.

Name	Description
UART1_TXD	UART1 transmit output
UART1_RXD	UART1 receive input
UART1_RTS	UART1 request to send output
UART1_CTS	UART1 clear to send input
UART1_DTR	UART1 data terminal ready output; A GPIO is used to emulate this function.
UART1_DSR	UART1 data set ready input; A GPIO is used to emulate this function.
UART1_DCD	UART1 data carrier detect input; A GPIO is used to emulate this function.
UART1_RI	UART1 ring indicator input; A GPIO is used to emulate this function.
UART2_TXD	UART2 transmit output
UART2_RXD	UART2 receive input
UART2_RTS	UART2 request to send output. This pin can be configured to be UART4_RXD.
UART2_CTS	UART2 clear to send input. This pin can be configured to be UART4_TXD.
UART3_TXD	UART3 transmit output; This signal is routed through the FPGA. If Trizeps module is without FPGA, there is a mounting option to either route UART3 to the SODIMM or to the BT-module.
UART3_RXD	UART3 receive input; This signal is routed through the FPGA. If Trizeps module is without FPGA, there is a mounting option to either route UART3 to the SODIMM or to the BT-module.
SPIN22_RTS3	UART3 request to send output; This signal is routed through the FPGA. If Trizeps module is without FPGA, there is a mounting option to either route UART3 to the SODIMM or to the BT-module. The SODIMM200-standard does not specify a RTS-pin for UART3.
SPIN24_CTS3	UART3 clear to send input; This signal is routed through the FPGA. If Trizeps module is without FPGA, there is a mounting option to either route UART3 to the SODIMM or to the BT-module. The SODIMM200-standard does not specify a CTS-pin for UART3.

Baudrate: High-speed TIA/EIA-232-F compatible, up to 1Mbit/s
IrDA-compatible, up to 115.2 Kbit/s

Data-Bits: 7 or 8 bits (RS232) or 9 bit (RS485)

Stop-Bits: 1, 2

Parity: None, Even, Odd

Features: Hardware-flow-control (RTS,CTS)



2.4 SPI

The serial peripheral interface is a programmable synchronous serial port, which may be used to connect to a multiple of different peripherals.

The i.MX8M features an Enhanced Configurable SPI (ECSPI).

The ECSPi2 is routed to the Kinetis MCU and to the FPGA.

The FPGA allows to route these signals to pins, that carried the SPI pins on previous Trizeps SODIMM200 modules. If no FPGA is mounted, there is a mounting option to route these signals to FPGA_CIF_VSYNC, FPGA_CIF_HSYNC, FPGA_CIF_MCLK and FPGA_CIF_PCLK.

Name	Description
SPI2_SS0	SPI2 Slave Select
SPI2_SCLK	SPI2 Clock
SPI2_MISO	SPI2 Master In Slave Out
SPI2_MOSI	SPI2 Master Out Slave In

Speed: up to 52Mbit/s

Features: Master & Slave mode

2.5 QSPI

The Quad Serial Peripheral Interface (QuadSPI) is a synchronous serial port with up to four bidirectional data lines to interface with external serial flash devices.

This interface is not part of the SODIMM200 standard.

Name	Description
QSPI_SS0	Quad SPI Slave Select
QSPI_SCLK	Quad SPI Clock
QSPI_DATA0	Quad SPI Data0
QSPI_DATA1	Quad SPI Data1
QSPI_DATA2	Quad SPI Data2
QSPI_DATA3	Quad SPI Data3

Speed: up to 50MHz

Features: Master only.

2.5 I2C

The Inter-Integrated Circuit (I2C) provides functionality of a standard I2C master and slave.

Name	Description
I2C2_SCL	Primary I2C; Clock
I2C2_SDA	Primary I2C; Data
I2C1_SCL	Secondary I2C; Clock
I2C1_SDA	Secondary I2C; Data

Speed: Standard mode, up to 100 kbit/s
Fast mode, up to 400 kbit/s

Features: Multimaster operation.
I²C Bus Specification Version 2.1



2.6 I2S

The Inter-IC sound interface provides a synchronous audio interface (SAI) and is used to connect to audio codecs.

This interface is not part of the SODIMM200 standard.

Name	Description
SAI1_TXC	Transmit Bit Clock
SAI1_TXFS	Transmit Frame Sync
SAI1_TXD0	Serial transmit data channel 0
SAI1_TXD1	Serial transmit data channel 1
SAI1_TXD2	Serial transmit data channel 2
SAI1_TXD3	Serial transmit data channel 3
SAI1_TXD4	Serial transmit data channel 4
SAI1_TXD5	Serial transmit data channel 5
SAI1_TXD6	Serial transmit data channel 6
SAI1_TXD7	Serial transmit data channel 7
SAI1_RXC	Receive Bit Clock
SAI1_RXFS	Receive Frame Sync
SAI1_MCLK	Audio Master Clock
SAI1_RXD0	Serial receive data channel 0
SAI1_RXD1	Serial receive data channel 1
SAI1_RXD2	Serial receive data channel 2
SAI1_RXD3	Serial receive data channel 3
SAI1_RXD4	Serial receive data channel 4
SAI1_RXD5	Serial receive data channel 5
SAI1_RXD6	Serial receive data channel 6
SAI1_RXD7	Serial receive data channel 7
BT_PCM_CLK	BT PCM clock (SAI3_RXC) Optional connected to BT module.
BT_PCM_SYNC	BT PCM Sync (SAI3_RXFS) Optional connected to BT module.
BT_PCM_IN	BT PCM In (SAI3_TXD) Optional connected to BT module.
BT_PCM_OUT	BT PCM Out (SAI3_RXD) Optional connected to BT module.



2.7 SD-Card

The SD-Card Interface may be used to connect a SD-Card, eMMC or SDIO-hardware to the Trizeps module.

Name	Description
SD2_CMD	SD-card command output
SD2_CLK	SD-card clock output
SD2_DAT0	SD-card data bit 0
SD2_DAT1	SD-card data bit 1
SD2_DAT2	SD-card data bit 2
SD2_DAT3	SD-card data bit 3
SD2_DET	SD-card detect: 1: card inserted, 0: card removed

Speed: Card bus clock frequency up to 208 MHz
Features: Conforms to the SD Host Controller Standard Specification version 3.0
Compatible with the MMC System Specification version 4.2/4.3/4.4/4.41/5.0
Compatible with the SD Memory Card Spec. version 3.0 and supports the Extended Capacity SD Memory Card
Compatible with the SDIO Card Specification version 3.0

2.8 USB

The Trizeps VIII Mini got one high-speed USB 2.0 OTG port which may work as host or as slave.

Name	Description
USB1_DP	USB1 Data Plus
USB1_DN	USB1 Data Negative
USB1_PEN	USB1 Power Enable output
USB1_OC	USB1 Overcurrent Detect input
USB1_VBUS	USB1 VBUS (+5V)
USB1_ID	USB1 ID Detect
USB2_DP	USB2 Data Plus
USB2_DN	USB2 Data Negative
USB2_PEN	USB2 Power Enable output
USB2_OC	USB2 Overcurrent Detect input

Speed: High-speed 480 Mbit/s
Full-speed 12 Mbit/s
Low-speed 1.5 Mbit/s
Features: Complies with USB specification rev 2.0 (xHCI compatible)



2.9 PCIe

The i.MX8M Mini features one PCI Express dual mode (DM) controller.

The PCIe port is connected to the internal Wireless module.

On modules without Wireless the signals are available on the SODIMM200 connector.

Name	Description
PCIE_REFCLK_N	PCIE Clock (negative)
PCIE_REFCLK_P	PCIE Clock (positive)
PCIE_TXN_N	PCIE Transmit Data (negative)
PCIE_TXN_P	PCIE Transmit Data (positive)
PCIE_RXN_N	PCIE Receive Data (negative)
PCIE_RXN_P	PCIE Receive Data (positive)
PCIE_WAKE	
PCIE_CLKREQ	

Speed: 1.5 / 2.5 / 3.0 / 5.0 / 6.0 Gbps
 Features: PCIe specification Gen2 x1 lane
 PCI Express 1.1/2.0 standard
 PCI Express Base Specification, Revision 4.0, Version 0.7
 PIPE Specification for PCI Express, Version 4.3
 PCI Local Bus Specification, Revision 3.0
 PCI Bus Power Management Specification, Revision 1.2

2.10 Ethernet

From V2Rx on Trizeps VIII Mini uses a Realtek RTL8211 integrated 10/100/1000 Mbps Ethernet transceiver to interface with the i.MX8M Mini RGMII.

In the older revisions V1Rx an Atheros (Qualcomm) AR8031 was used.

Name	Description
ETH_TRX0_N	Ethernet Transmit/Receive Data 0 (negative)
ETH_TRX0_P	Ethernet Transmit/Receive Data 0 (positive)
ETH_TRX1_N	Ethernet Transmit/Receive Data 1 (negative)
ETH_TRX1_P	Ethernet Transmit/Receive Data 1 (positive)
ETH_TRX2_N	Ethernet Transmit/Receive Data 2 (negative)
ETH_TRX2_P	Ethernet Transmit/Receive Data 2 (positive)
ETH_TRX3_N	Ethernet Transmit/Receive Data 3 (negative)
ETH_TRX3_P	Ethernet Transmit/Receive Data 3 (positive)
ETH_LED_LINK_AKT	LED output for 10/100/1000 BASE-T activity
ETH_LED_SPEED	LED output for 10 / 100 BASE-T link
ETH_LED_SPEED1000	LED output for 1000 BASE-T link
VDD_ENET_IO	+2V5 IO-voltage output.

In addition to the normal copper interface, the transceiver incorporates a 1.25GHz SerDes. This interface can be connected directly to a fiber-optic transceiver for 1000 BASE-X / 100 BASE-FX mode or to MAC-device for SGMII interface.



Name	Description
ETH_SI_N	SGMII/1000FX Input (negative)
ETH_SI_P	SGMII/1000FX Input (positive)
ETH_SO_N	SGMII/1000FX Output (negative)
ETH_SO_P	SGMII/1000FX Output (positive)

2.11 CAN

The CAN interface of the Trizeps VIII Mini is implemented through the Kinetis Cortex M0+ MCU.

Name	Description
CAN1_RX	CAN1 Receive Data
CAN1_TX	CAN1 Transmit Data

2.12 Display

The i.MX8M processor has this display interfaces:

- DSI-MIPI (4ch)

The DSI-MIPI interface can be converted to:

- Single-/Dual-LVDS (through on board MIPI->LVDS transceiver)
- parallel RGB Display (through on board FPGA)

Name	Description
DISPLAY_ENABLE	This GPIO is typical used to control the display-enable signal of an attached display.
BACKLIGHT_PWM	This GPIO is capable of generating a PWM and is typical used to generate the backlight PWM signal.

2.12.1 DSI-MIPI (4ch)

The DSI-MIPI signals are routed to an FPGA, MIPI->LVDS Transceiver and to the B2B-connector.

Name	Description
MIPI_DSI_CLK_P	DSI Clock (positive)
MIPI_DSI_CLK_N	DSI Clock (negative)
MIPI_DSI_D0_P	DSI Data 0 (positive)
MIPI_DSI_D0_N	DSI Data 0 (negative)
MIPI_DSI_D1_P	DSI Data 1 (positive)
MIPI_DSI_D1_N	DSI Data 1 (negative)
(MIPI_DSI_D2_P) LVDS1_TX1_P	DSI Data 2 (positive); This is a mounting option (RA4), to route this pin to the B2B-connector, when no LVDS-transceiver is used.



(MIPI_DSI_D2_N) LVDS1_TX1_N	DSI Data 2 (negative); This is a mounting option (RA4), to route this pin to the B2B-connector, when no LVDS-transceiver is used.
(MIPI_DSI_D3_P) LVDS1_TX0_P	DSI Data 3 (positive); This is a mounting option (RA4), to route this pin to the B2B-connector, when no LVDS-transceiver is used.
(MIPI_DSI_D3_N) LVDS1_TX0_N	DSI Data 3 (negative); This is a mounting option (RA4), to route this pin to the B2B-connector, when no LVDS-transceiver is used.

Speed: Support 80Mbps – 1.5Gbps data rate in high speed operation
Support 10Mbps data rate in low power operation.
Features: Compliant to MIPI-DSI standard v1.1

2.12.2 Single-/Dual LVDS

The Trizeps VIII Mini can be equipped with a QuickLogic ArctikLink III (Single- and Dual LVDS) MIPI DSI to LVDS bridge.

In older revisions V1Rx the conversion was done with TI SN65DSI83 (Single-LVDS) or SN65DSI85 (Dual-LVDS) MIPI DSI to LVDS bridge. For SN65DSI83 mounting option, only channel A could be used.

Name	Description
LVDS0_CLK_P	Channel A LVDS Clock (positive)
LVDS0_CLK_N	Channel A LVDS Clock (negative)
LVDS0_TX0_P	Channel A LVDS Data 0 (positive)
LVDS0_TX0_N	Channel A LVDS Data 0 (negative)
LVDS0_TX1_P	Channel A LVDS Data 1 (positive)
LVDS0_TX1_N	Channel A LVDS Data 1 (negative)
LVDS0_TX2_P	Channel A LVDS Data 2 (positive)
LVDS0_TX2_N	Channel A LVDS Data 2 (negative)
LVDS0_TX3_P	Channel A LVDS Data 3 (positive)
LVDS0_TX3_N	Channel A LVDS Data 3 (negative)
LVDS1_CLK_P	Channel B LVDS Clock (positive)
LVDS1_CLK_N	Channel B LVDS Clock (negative)
LVDS1_TX0_P	Channel B LVDS Data 0 (positive)
LVDS1_TX0_N	Channel B LVDS Data 0 (negative)
LVDS1_TX1_P	Channel B LVDS Data 1 (positive)
LVDS1_TX1_N	Channel B LVDS Data 1 (negative)
LVDS1_TX2_P	Channel B LVDS Data 2 (positive)
LVDS1_TX2_N	Channel B LVDS Data 2 (negative)
LVDS1_TX3_P	Channel B LVDS Data 3 (positive)
LVDS1_TX3_N	Channel B LVDS Data 3 (negative)



2.12.3 Parallel RGB Display

The Trizeps VIII Mini can be equipped with a Lattice MachXO3 FPGA with up to 4300LUT. This FPGA may be programmed to convert the MIPI-DSI data stream into parallel display output. Although this allows flexible pinning, it is recommended to follow the Trizeps SODIMM200 standard.

Name	Description		
FPGA_LCD_PCLK	Pixel-Clock		
FPGA_LCD_DE	Data-Enable / Data-Valid		
FPGA_LCD_HSYNC	Horizontal Sync		
FPGA_LCD_VSYNC	Vertical Sync		
FPGA_LCD_D00	blue [0]		
FPGA_LCD_D01	blue [1]		
FPGA_LCD_D02	blue [2]		
FPGA_LCD_D03	blue [3]		
FPGA_LCD_D04	blue [4]		
FPGA_LCD_D05	24bpp: blue [5]	18bpp: blue [5]	16bpp: green [0]
FPGA_LCD_D06	24bpp: blue [6]	18bpp: green [0]	16bpp: green [1]
FPGA_LCD_D07	24bpp: blue [7]	18bpp: green [1]	16bpp: green [2]
FPGA_LCD_D08	24bpp: green [0]	18bpp: green [2]	16bpp: green [3]
FPGA_LCD_D09	24bpp: green [1]	18bpp: green [3]	16bpp: green [4]
FPGA_LCD_D10	24bpp: green [2]	18bpp: green [4]	16bpp: green [5]
FPGA_LCD_D11	24bpp: green [3]	18bpp: green [5]	16bpp: red [0]
FPGA_LCD_D12	24bpp: green [4]	18bpp: red [0]	16bpp: red [1]
FPGA_LCD_D13	24bpp: green [5]	18bpp: red [1]	16bpp: red [2]
FPGA_LCD_D14	24bpp: green [6]	18bpp: red [2]	16bpp: red [3]
FPGA_LCD_D15	24bpp: green [7]	18bpp: red [3]	16bpp: red [4]
FPGA_LCD_D16	24bpp: red [0]	18bpp: red [4]	
FPGA_LCD_D17	24bpp: red [1]	18bpp: red [5]	
FPGA_LCD_D18	24bpp: red [2]		
FPGA_LCD_D19	24bpp: red [3]		
FPGA_LCD_D20	24bpp: red [4]		
FPGA_LCD_D21	24bpp: red [5]		
FPGA_LCD_D22	24bpp: red [6]		
FPGA_LCD_D23	24bpp: red [7]		



2.13 Camera

The i.MX8M Mini Processor got one MIPI CSI camera interface. It is connected to the B2B-connector.

In earlier versions the second MIPI CSI camera interface (CSI2) was connected to the on-board FPGA and a mounting option existed to connect it to the MIPI CSI1 signals.

Name	Description
MIPI_CSI1_CLK_N	Main camera clock input – negative
MIPI_CSI1_CLK_P	Main camera clock input – positive
MIPI_CSI1_D0_N	Main camera data lane 0 – negative
MIPI_CSI1_D0_P	Main camera data lane 0 – positive
MIPI_CSI1_D1_N	Main camera data lane 1 – negative
MIPI_CSI1_D1_P	Main camera data lane 1 – positive
MIPI_CSI1_D2_N	Main camera data lane 2 – negative
MIPI_CSI1_D2_P	Main camera data lane 2 – positive
MIPI_CSI1_D3_N	Main camera data lane 3 – negative
MIPI_CSI1_D3_P	Main camera data lane 3 – positive

Speed: Support 80Mbps – 1.5Gbps data rate in high speed operation
Support 10Mbps data rate in low power operation.

Features: up to 4-lane; 1.5 Gbps per lane,
Support up to 1080p@60fps video capture.

Name	Description
CSI1_PWDN	This GPIO is typical used to control the Power-Down pin of a camera.
CSI_RESET	This GPIO is typical used to control the Reset-pin of a camera.

The Trizeps VIII Mini could be equipped with a Lattice MachXO3 FPGA with up to 4300LUT. In earlier versions (up to V1R3), this FPGA could be programmed to convert parallel camera data into a MIPI CSI data stream that could be read by the i.MX8M Mini when the CSI2 to CSI1 mounting option was installed. The FPGA_CIF_XXX pins were additionally connected to the SAI interface of the i.MX8M Mini



2.14 Wireless

The Trizeps VIII Mini may be equipped with a HD Wireless SPB228, Silex SX-PCEAC2 or AzureWave CM276NF module.

The antennas are connected directly to the module.

2.15 Audio

Name	Description
AUDIO_MIC_OUT	Main Microphone input
AUDIO_MIC_GND	Microphone ground
AUDIO_LINEIN_L	LineIn left channel input
AUDIO_LINEIN_R	LineIn right channel input
AUDIO_HEADPHONE_L	Headphone left channel output
AUDIO_HEADPHONE_R	Headphone right channel output
AUDIO_HEADPHONE_GND	Headphone ground sensing input
SPEAKER_P	Class-D speaker amp + output
SPEAKER_N	Class-D speaker amp – output
AUDIO_ENABLE	This GPIO is typical used to control the enable pin of an external audio-amplifier connected to the AUDIO_HEADPHONE pins.

2.16 SPDIF

The i.MX8M Mini supplies a Sony/Philips Digital Interface (SPDIF) stereo transceiver that allows the processor to receive and transmit digital audio.

Name	Description
SPDIF_IN	SPDIF input
SPDIF_OUT	SPDIF output
SPDIF_EXT_CLK	SPDIF clock



3 SPECIFICATIONS

3.1 Absolute Maximum Ratings

Absolute maximum ratings reflect conditions that the module may be exposed outside of the operating limits, without experiencing immediate functional failure. Functional operation is only expected during the conditions indicated under “Recommended Operating Conditions”. Stresses beyond those listed under “Absolute Maximum Ratings” may cause permanent damage to the module. Exposure to absolute-maximum rated conditions for extended periods may affect device reliability.

	Pin	Min		Max	Unit
Supply Voltage	+3V3_SNVS	-0.3		3.8	V
	+3V3	-0.3		4.0	V
	AUDIO_VDD	-0.3		4.5	V
	AVDD_SPEAKER	-0.3		7.0	V
Storage Temperature	T _{Storage}	-40		+85	°C

3.2 Recommended Operating Conditions

	Pin	Min	Typ	Max	Unit
Supply Voltage	+3V3_SNVS	3.1	3.3	3.4	V
	+3V3	3.1	3.3	3.4	V
	AUDIO_VDD	2.8	3.3	3.4	V
	AVDD_SPEAKER	2.8	3.3	5.0	V
Supply current (typ.) Power consumption dramatically depends on the usage scenario. This includes things like if the processors operating point (frequency) can be set to a lower level; if the GPU can be used by an application; the selected display-resolution or if the module supplies external peripherals i.e. a speaker or if the PMIC charges a battery. We recommend to use a 2A voltage-regulator to supply the module.	@ 3.3V Idle Using/Running Typ. Peak Currents when running.		tbd tbd tbd		mA mA A
Operating temperature The chip temperature of processor or LPDDR4 might get hotter. The max. case temperature of i.MX 8M Mini is specified with +95°C (consumer) and +105°C (industrial). A higher refresh-rate-setting is needed when case temperature of LPDDR4 is expected to rise above +85°C. Temperature of eMMC influence the achievable Data Retention.	T _{Consumer} T _{Extended} T _{Industrial}	0 -25 -40	+25 +25 +25	+85 +85 +85	°C °C °C



3.3 ESD Ratings

		Max	Unit
V _(ESD) Electrostatic discharge	Human body model (HBM)	±1000	V
	Charged-device model (CDM)	±250	V

3.4 Electrical Characteristics

3.4.1 i.MX 8M Mini GPIO DC parameters. Please view i.MX 8M Mini datasheet for details:

	Parameter	Min	Max	Unit
V _{IL_3V3}	Low-level input voltage	-0.3	0.3 x VDD	V
V _{IH_3V3}	High-level input voltage	0.7 x VDD	VDD + 0.3	V
V _{OH_3V3}	High-level output voltage	0.8 x VDD	VDD	V
V _{OL_3V3}	Low-level output voltage	0	0.2 x VDD	V
R _{P_up}	Pull-Up Resistance (1)	18	72	kΩ
R _{P_down}	Pull-Down Resistance (1)	24	87	kΩ

- (1) The i.MX 8M Mini does not support internal pull-up/down for VDD=3.3V.
- (2) The state of the GPIO-pins is undefined until the PMIC has powered-up and +3V3_AUX is supplied.

3.4.2 FPGA single-Ended DC parameters. Please view FPGA datasheet for details:

	Parameter	Min	Max	Unit
V _{IL_3V3}	Low-level input voltage	-0.3	0.8	V
V _{IH_3V3}	High-level input voltage	2.0	3.6	V
V _{OH_3V3}	High-level output voltage	VCC-0.2 (I _{OH} =-100μA) VCC-0.4 (I _{OH} =-16mA)	-	V
V _{OL_3V3}	Low-level output voltage	-	0.2 (I _{OL} =100μA) 0.4 (I _{OL} =16mA)	V
I _{PU}	Pull-Up Current	-30	-309	μA
I _{PD}	Pull-Down Current	30	305	μA

3.4.3 Cortex M0+ MCU DC parameters. Please view MCU datasheet for details:

	Parameter	Min	Max	Unit
V _{IL_3V3}	Low-level input voltage	-	0.35 x VCC_SNVS	V
V _{IH_3V3}	High-level input voltage	0.7 x VCC_SNVS	-	V
V _{OH_3V3}	High-level output voltage	VCC-0.5 (I _{OH} =-5mA) VCC-0.5 (I _{OH} =-18mA)	-	V
V _{OL_3V3}	Low-level output voltage	-	0.5 (I _{OL} =5mA) 0.5 (I _{OL} =18mA)	V
I _{OHT}	Output high current total for all ports	-	100	mA
I _{OLT}	Output low current total for all ports	-	100	mA
R _{PU}	Internal pullup resistor	20	50	kΩ

3.5 Mechanical Specification

Dimensions (mm) of the Trizeps VIII Mini module (top view)

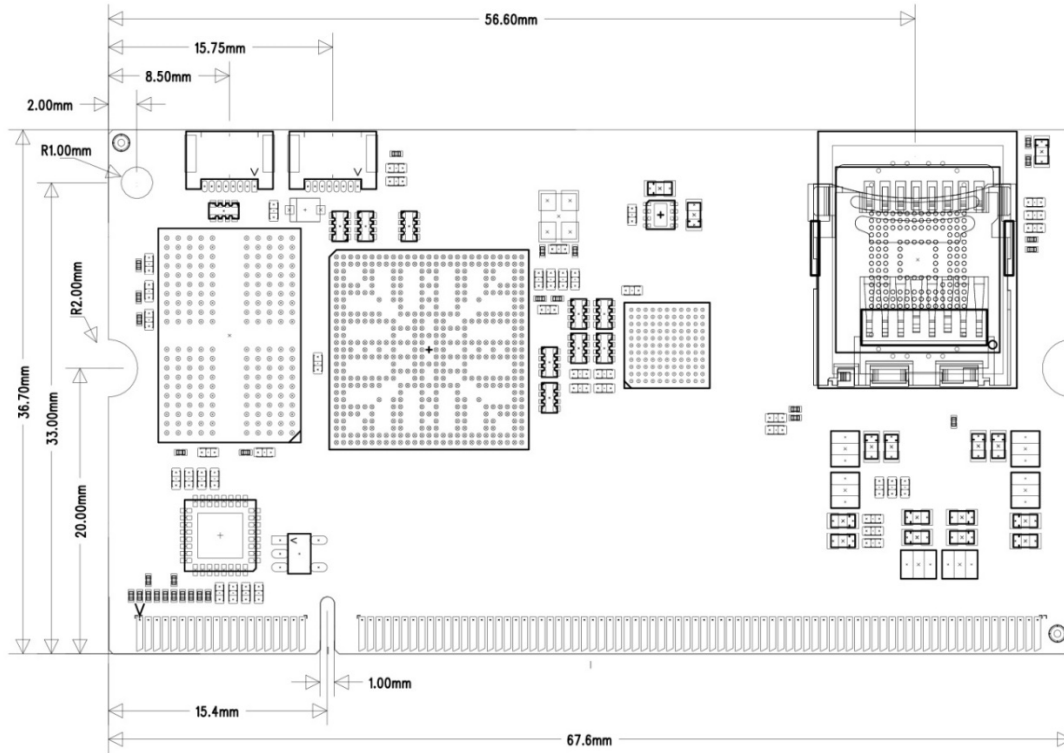

Dimensions (mm) of the Trizeps VIII Mini module (bottom view)

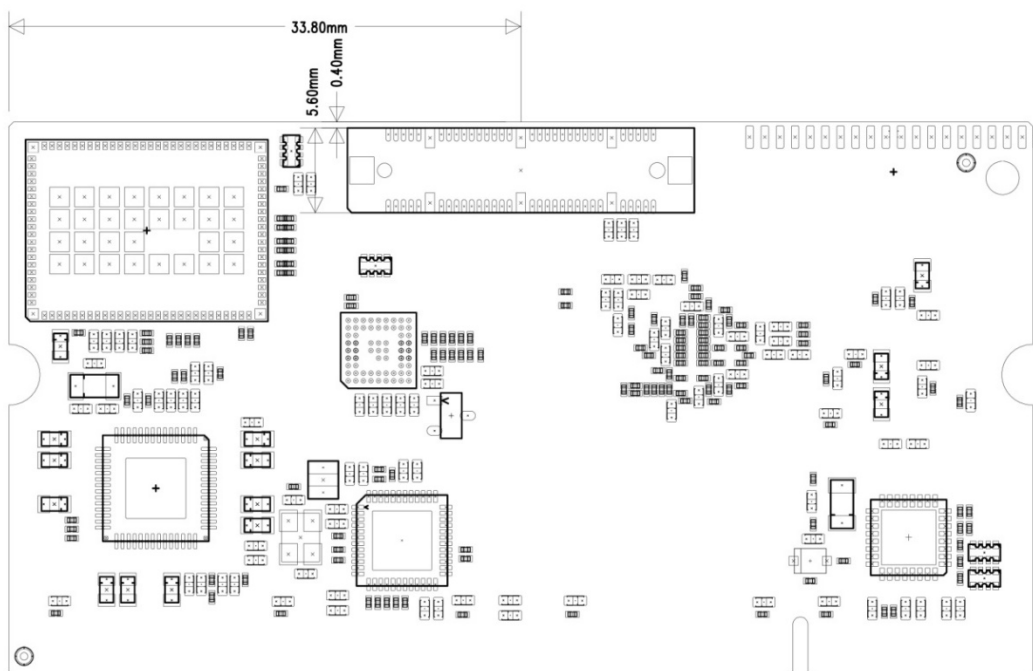



4 ARTICLE NUMBERS FOR TRIZEPS VIII MINI

1-2	3	4	5	6	7	8	9	10	11	12	13-15	16-18
59	Processor	RAM	PCB	.	Temp	FP GA	Peripher al	Ethernet/ WLAN	Store	.	Hxx	Syy
59	A	2	0	.	C	2	B	3	2	.	H00	S00

Processor:

- 0 1.8GHz SoloLite CT
- 1 1,6GHz SoloLite IT
- 2 1.8GHz Solo CT
- 3 1.6GHz Solo IT
- 4 1.8GHz DualLite CT
- 5 1.6GHz DualLite IT
- 6 1.8GHz Dual CT
- 7 1.6GHz Dual IT
- 8 1.8GHz QuadLite CT
- 9 1.6GHz QuadLite IT
- A 1.8GHz Quad CT
- B 1.6GHz Quad IT

RAM:

- 0 512 MB
- 1 1 GB
- 2 2 GB
- 4 4 GB
- 8 8 GB

PCB Revision:

- 0 V1R1L1
- 1 V1R2L1
- 2 V1R3L1
- 3 V2R1L1
- 4 V2R2L1
- 5 V3R1L1

Temperature:

- C 0 .. 70°C
- E -25 .. 85°C
- I -40 .. 85°C

FPGA:

- 0 No FPGA
- 1 LCMX03LF-1300E
- 2 LCMX03LF-2100E
- 3 LCMX03LF-4300E
- 4 LCMX03L-1300E
- 5 LCMX03L-2100E
- 6 LCMX03L-4300E

Software/Firmware:

- S00 Standard Software
- S01 ...

Hardware:

- H00 Standard
- H01 ... Defines custom mounting options

Storage:

- 0 uSD-Card-Socket
- 1 eMMC 4GB, MLC
- 2 eMMC 8GB, MLC
- 3 eMMC 16GB, MLC
- 4 eMMC 32GB, 3D

Ethernet/WLAN:

- 0 no Ethernet, no WLAN
- 1 with Ethernet, no WLAN
- 2 no Ethernet, with WLAN1
- 3 with Ethernet, with WLAN1
- 4 no Ethernet, with WLAN2
- 5 with Ethernet, with WLAN2

WLAN1: HD-Wireless SPB228
WLAN2: Silex SX-PCEAC2
WLAN3: AzureWave CM276

Peripheral:

- 0 no LVDS, no Audio, no MCU
- 1 no LVDS, no Audio, with MCU (no CAN)
- 2 no LVDS, no Audio, with MCU (CAN)
- 3 no LVDS, with Audio, no MCU
- 4 no LVDS, with Audio, with MCU (no CAN)
- 5 no LVDS, with Audio, with MCU (CAN)
- 6 with LVDS, no Audio, no MCU
- 7 with LVDS, no Audio, with MCU (no CAN)
- 8 with LVDS, no Audio, with MCU (CAN)
- 9 with LVDS, with Audio, no MCU
- A with LVDS, with Audio, with MCU(no CAN)
- B with LVDS, with Audio, with MCU (CAN)
- C with Dual-LVDS, no Audio, no MCU
- D with Dual-LVDS, no Audio, MCU(no CAN)
- E with Dual-LVDS, no Audio, MCU (CAN)
- F with Dual-LVDS, with Audio, no MCU
- G with Dual-LVDS, with Audio, MCU(no CAN)
- H with Dual-LVDS, with Audio, MCU (CAN)

LF: infinitely reconfigurable Flash
L: multi-time (up to 8x) configurable NVCM

Audio-Codec:
WM8983 (C+E Temp) (up to revision V2R2)
WM8978 (I Temp) (up to revision V2R2)
WM8962B (from revision V3R1)



Examples article numbers

Article number 00...	Trizeps VIII Mini
59 B21.E0912. H00S00	Trizeps VIII Mini EC/ Quad/IT1600/R2G/EMMC8G/ LVDS/ETH/COD/RoHS (Extended Consumer Temperature -25 to 85°C, i.MX 8M Mini Quad Core, IT 1.6 GHz, 2 GB RAM, 8 GB eMMC, LVDS, Ethernet, Codec)
59 A21.C2B32. H00S00	Trizeps VIII Mini CT/Quad/ C01800/R2G/EMMC8G/FPGA/LVDS/ETH/COD/MCU/WB/RoHS (Consumer Temperature 0 to 70°C, i.MX 8M Mini Quad Core, C0 1.8 GHz, 2 GB RAM, 8 GB eMMC, FPGA LF21, LVDS, Ethernet, Codec, Kinetis MCU, WLAN, BT)

Other versions on request

5 IMPORTANT NOTICE



6 DOCUMENT HISTORY

Rev.	Date	Author	Changes
0.9	17.04.2019	VoB	Initial version
1.0	23.05.2019	SH	Added graphics. Corrected some parts.
1.1	16.10.2019	SH	Updated "4.0 Ordercodes for Trizeps VIII Mini" Updated Temperature and ESD specification. Added remark about i.MX 8M Mini not supporting internal pull-up/down for 3.3V IO-Voltage. Changed RESET_OUT: gpio1.IO[2] to gpio3.IO[14] (V1R1L' -> V1R2L1)
1.2	23.10.2019	SH	Added comment PCIE_CLKREQ signal (SODIMM 115) may not be used when Wifi-module is mounted. V1R1 -> V1R2 change of PCIE_CLKREQ pin form GPIO5_21 to GPIO5_20.
1.3	18.11.2019	SH	Corrected Feature list that i.MX 8M Mini is used.
1.4	11.12.2019	TW/CT	Updated "4.0 Article numbers for Trizeps VIII Mini". Layout modifications
1.5	06.04.2019	SH	Added info to available Excel-Sheet and GPIO-behaviour during startup.
1.6	06.07.2020	TW	Changed WiFi Connector from UFL to µRF.
1.7	15.10.2020	SH	Fix wrong reference (changed RA438 to RA3)
1.8	30.10.2020	SH	Chapter 2.12.2; Fix description: (MIPI_DSI_D3_N) is "DSI Data 3 (negative)"
2.0	21.11.2022		Update new CI
3.0	08.05.2023	VoB	Refers to hardware revision V2 and V3 Major changes: <ul style="list-style-type: none">- J400 B2B connector assignment- J500 SODIMM connector assignment
3.1	22.03.2024	MS	Changed Name B..... to BT

SECO Northern Europe GmbH

Schlachthofstraße 20
21079 Hamburg

E-Mail: north@seco.com

<https://north.seco.com>

All rights reserved. Products subject to technical changes, improvements and misprints.
© 2022 SECO Northern Europe GmbH